



TYP FV-EU

PRZECIWPOŻAROWE ZAWORY DO NAWIEWU I WYWIEWU POWIETRZA

Circular fire protection valve for the isolation of duct penetrations between fire compartments; suitable for supply air and extract air systems. They also satisfy ventilation requirements

- Nominal sizes Ø 100, 125, 160, 200 mm
- For installation in walls and ceilings
- Low differential pressure and sound power level
- Integration into the central BMS with TROXNETCOM

Optional equipment and accessories

- Electric limit switch
- Extension piece
- Trim ring, circular or square

Application



Application

- Fire protection valves of Type FV-EU, with CE marking and declaration of performance, for the isolation of duct penetrations between fire compartments in the event of a fire
- To prevent the propagation of fire and smoke through ductwork to adjacent designated fire compartments

Special characteristics

- Declaration of performance according to Construction Products Regulation
- Classification to EN 13501-3, up to EI 120 (ve, ho, i ↔ o) S
- Building inspectorate licence Z-56.4212-991, non-combustible and non-hazardous to health
- Complies with the requirements of EN 15650
- Tested to EN 1366-2 for fire resistance properties
- Hygiene complies with VDI 6022 part 1 (07/ 2011), VDI 3803 (10/2002), DIN 1946 part 4 (12/2008), and EN 13779 (09/2007)
- Corrosion protection according to EN 15650 in connection with EN 60068-2-52
- Closed valve cone air leakage to EN 1751, class 2
- Low differential pressure and sound power level

Description



Variants

- With fusible link
- With fusible link and limit switch

Attachments

- Limit switch for capturing the valve position

Accessories

Mortar-based installation

- Trim ring, circular
- Trim ring, square

Construction features

- Adjustment device for large or small air volumes
- Valve cone with bayonet fixing

Materials and surfaces

- Installation subframe, spigot and valve disc made of sheet steel
- Installation subframe and spigot with stove- enamelled finish, black
- Exposed surface of valve disc powder-coated RAL 9010
- Valve cone made of special insulation material
- Seal made of polyurethane
- Attachments made of galvanised steel
- Increased corrosion protection due to powder- coated casing

INFORMACJE TECHNICZNE

Functional description

In the event of a fire, fire protection valves shut automatically to prevent the propagation of fire and smoke through ductwork to adjacent designated fire compartments. In the event of a fire, the valve is triggered at 72 °C by a fusible link. The release mechanism is accessible and can be tested from the outside

Schematic illustration of the FV-EU with extension piece and limit switches

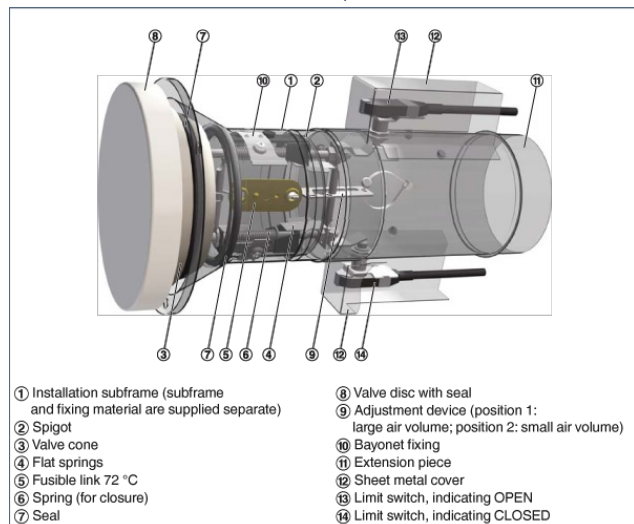

Nominal sizes	Ø 100, 125, 160, 200 mm
Casing length	150 mm (320 mm with extension)
Release temperature	72 °C
Operating temperature	0 – 50 °C
Volume flow rate range	Extract air up to 350 m ³ /h or supply air up to 400 m ³ /h

Fire protection valve for the isolation of duct penetrations between fire compartments. For use in supply air and extract air systems; with two-stage adjustment device for adjusting the air volume. Ready-for-operation unit, which includes a fire-resistant valve cone and a release mechanism. Tested for fire resistance properties to EN 1366-2, with CE marking and declaration of performance according to the Construction Products Regulation. For mortar-based installation into solid walls and ceiling slabs, and into lightweight partition walls with metal support structure and cladding on both sides. Casing length of 150 mm, or 320 mm with extension piece For the connection to ducts made of non-combustible or combustible materials. Thermal release at 72 °C.

Special characteristics

- Declaration of performance according to Construction Products Regulation
- Classification to EN 13501-3, up to EI 120 (ve, ho, i ↔ o) S
- Building inspectorate licence Z-56.4212-991, non-combustible and non-hazardous to health
- Complies with the requirements of EN 15650
- Tested to EN 1366-2 for fire resistance properties
- Hygiene complies with VDI 6022 part 1 (07/ 2011), VDI 3803 (10/2002), DIN 1946 part 4 (12/2008), and EN 13779 (09/2007)
- Corrosion protection according to EN 15650 in connection with EN 60068-2-52
- Closed valve cone air leakage to EN 1751, class 2
- Low differential pressure and sound power level
- Any airflow direction

Materials and surfaces

- Installation subframe, spigot and valve disc made of sheet steel
- Installation subframe and spigot with stove- enamelled finish, black
- Exposed surface of valve disc powder-coated RAL 9010
- Valve cone made of special insulation material
- Seal made of polyurethane
- Attachments made of galvanised steel
- Increased corrosion protection due to powder- coated casing

Technical data

- Nominal sizes: Ø 100, 125, 160, 200 mm
- Casing length:
150 mm, or 320 mm with extension piece
- Release temperature: 72 °C
- Operating temperature: 10 to 50 °C
- Volume flow rate range: Extract air up to 350 m³/h or supply air up to 400 m³/h

FV-EU

FV – EU / DE / 160 / R / Z05
--

1 Type
FV-EU Fire protection valve

2 Country of destination
DE Germany
 Other destination countries upon request

4 Accessories
 No entry: none
R Trim ring - circular
Q Trim ring - square

3 Nominal size [mm]
 100
 125
 160
 200

5 Attachments
Z04 – Z07